

# SINOVO

# SINOVO



Please scan the QR code for  
the latest information about SINOVO Electric

AC DRIVE/SD600



Version: A01

## SINOVO QUALITY PROFESSIONAL QUALITY



- In 2006** Shenzhen Sinovo Electric Technologies Co., Ltd was established.
- 200+** Member of staffs
- 30+** Establishment of offices in main cities
- 100+** More than 100 cities have established after sales services centers

**SINOVO, established in 2006.**  
**It is a national high- tech enterprise integrating R&D, production, sales and service.**

- With more than 200 employees, one third of them are R&D engineers.
- Shenzhen R&D/ sales headquarters, with 8000 square meters factory in heyuan. More than 30 main cities have established offices, over 100 cities have after- services center.
- The products sell to all over the world. Main market is Europe, Asia, America and Africa.

### Quality

- National high- tech enterprise
- Post- doctoral innovation practice base Shenzhen software enterprise

### Achievement

- Obtained more than ten financial incentives and policy support for energy conservation and environmental protection, technology development, advanced manufacturing, etc. from Shenzhen City and Baoan District Governments
- Applied more than 30 invention patents, utility model patents, appearance patents, software copyrights, etc. with the State Intellectual Property Office.

### Corporate Culture

- **Spirit:**  
We are honest and devoted
- **Service Objective:**  
We believe in customer first, let's work hand in hand for win win cooperation
- **Vision:**  
We delicate ourself to becoming globally leading & trustworthy supplier in industrial automation and new energy field.

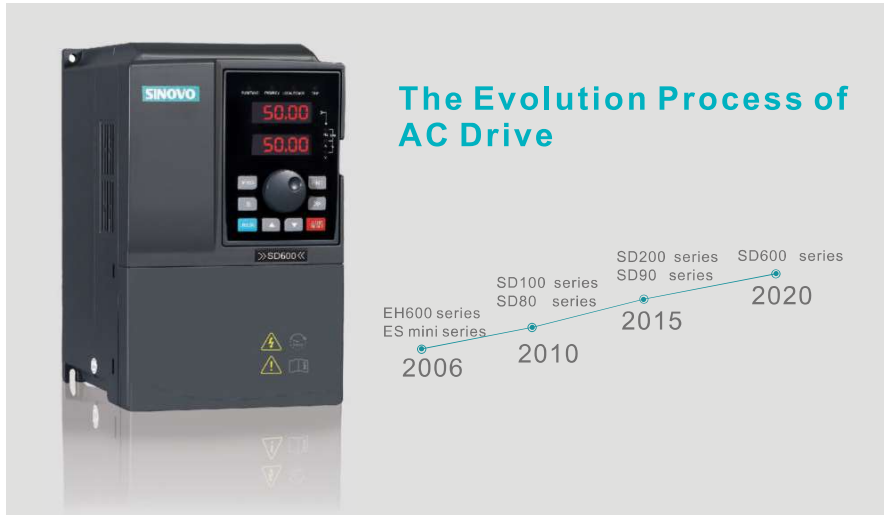

## SD600 Series SINOVO

Based on many years of research and development technology achievements and market feedback, SD600 series AC Drive have been fully upgraded in terms of structure, hardware and software on the basis of the excellent previous work.

### High Power Density:

The structure design layout is more compact;

### High Quality:

The hardware design and components selection are more optimized and reasonable;

### High Performance:

The software upgrade is more compatible with the end user, industrial control is more flexible, accurate, and the performance is stronger, and it is more suitable for precision control occasions with higher requirements for torque, control accuracy, and response speed;

### Optimize Products User Experience:

Easy operation, maintainability, environmental protection, scalability and convenience of Internet of Things access;

## High Performance

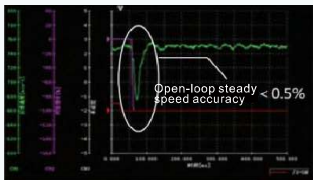

### 1. High Speed Stability and Precision

±0.5%(SVC), ±0.02%(FVC)  
VC dynamic speed stability accuracy (speed anti-load disturbance): 0.103%

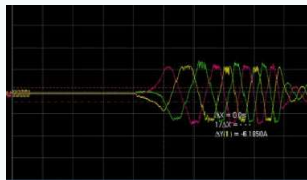

### 2. Fast Current Limit

The Drive has a combination of software and hardware fast current limiting functions. When it detects that the current of each phase is more than the limit value, it quickly completes the wave-by-wave current limiting control to avoid over-current faults.

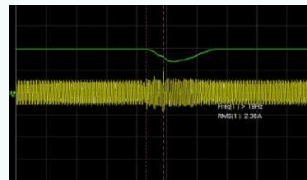

### 3. Instant Power Failure Without Stopping

When the power failure instantly, the Drive realizes generation feedback by reducing the operating frequency and maintains the stability of the bus voltage. When the grid input is normal, it returns to normal operation.

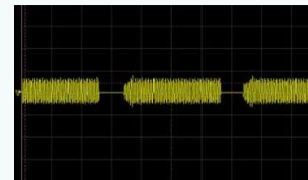

### 4. Fast Rotary Speed Tracking

The Drive completes the speed tracking of the shaft of the high-speed rotating motor within 300ms, realizing fast and smooth start.

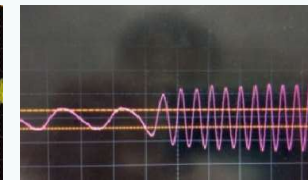

### 5. Excellent Low Frequency Torque Control

0.5HZ applied load during smooth operation

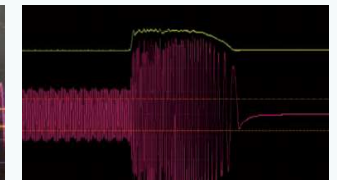

### 6. Overexcitation Function

There is no need to add external braking resistors and other components to achieve rapid braking effect, which can effectively suppress the rise of bus voltage during deceleration, avoid frequent overvoltage faults, and cooperate with the software's overvoltage suppression algorithm to meet rapid shutdown.

### ▶ Large Torque at Low Speed, Small Torque Ripple

In closed-loop vector mode, the linearity deviation of the torque straight line is within 3%. The torque output is stable, the low-frequency torque is large, and it can realize the stable load operation at an ultra-low speed of 0.01Hz. The torque mode and the speed mode can be easily switched.

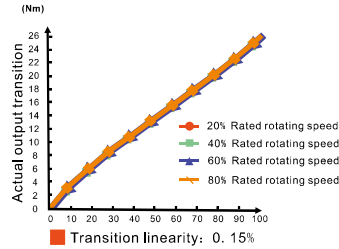

### ▶ Over Voltage and Current Control

#### Over - voltage Stalled

In the deceleration process, by adjusting the output frequency, avoid excessive deceleration that causes the motor to generate too much power, which may cause over voltage on the main branch bus of the Drive.



#### Over - current Stalled

During the acceleration process, by adjusting the output frequency, avoid excessive acceleration caused by excessive load, which may cause a large over current of the inverter.

### ▶ Multiple Application Functions

Improved V/F	SVC	FVC	MODBUS\CAN\CAN open\Profi Bus
Multi-speed control	I/O optional card	switch 1st and 2nd commands	
Parameter copy Speed search start	Accurate self-identification	Frequency binding	
Function code display hidden function	PID	FDI	S curve Power down and restart
Outstanding weak magnetic field control	V/F separation control	Overexcitation braking	
DC braking	Current limit protection	Stalled protection	
Motor thermal protection Counting function	.....		

## ▶ Advanced Design

### ▶ Over Voltage and Current Control

Long lifespan component selection and refined design ensured the good quality of the products.

Stabilize the automatic spraying process of the three- proof paint, increase the environmental resistance of the veneer, and comprehensively improve the protection of the veneer.



### ▶ Perfect DC Braking Circuit Scheme

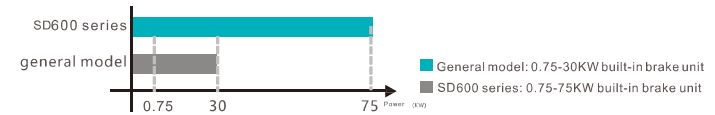

0.75kW~75kW built-in brake unit Strong braking ability: The short-term braking ability can reach 1.1~1.4 times the rated power of the Drive, and the braking protection is more comprehensive and intelligent.

### ▶ Perfect DC Braking Circuit Scheme

All models with standard DC power supply terminals

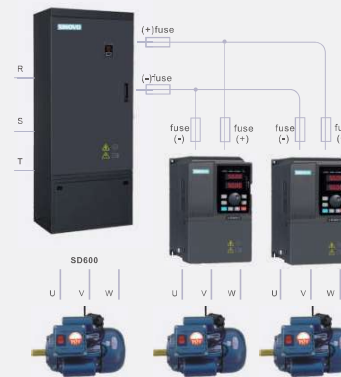

### ▶ Multiple Communications

Standard MODBUS communication, optional PROFIBUS and CANOPEN communication card. It can connect the IOT via communication mode.

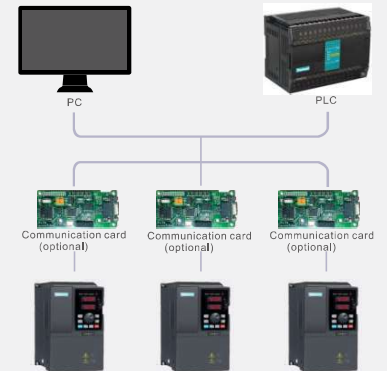

## Rich Scalability

Various function expansion cards , IO cards , relay output cards , and various PG cards can be selected according to requirements to match various encoders , communication expansion cards , etc. Can be customized according to demand.

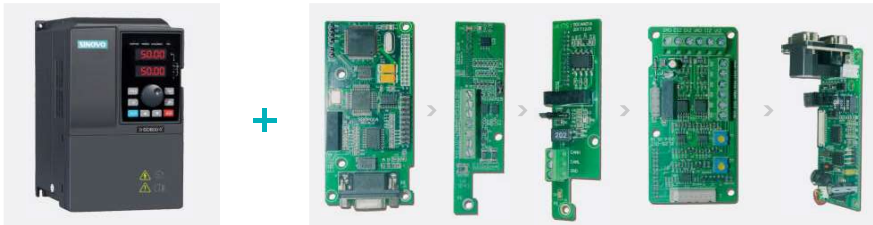

## High-Performance Keypad

### High-performance Keypad( standard)

Double- row LED display, convenient for parameter monitoring;

With parameter copy and upload functions



### LCD Keypad (optional)

Full display of each parameter description, Support multilingual;

With parameter copy and upload functions



## Reasonable Structural Design



### 1. Independent Air Duct Design

It prevent pollutants from entering the electronic component, effectively improve the protective level of Drive, so as to adapt to the various complex and harsh application environment. It improve the reliability of the product and extend the inverter lifespan; The independent air duct effectively solves the large heat dissipation problem in the control cabinet, which is convenient for customers' electrical cabinet heat dissipation design.

### 2. Advanced Thermal Simulation Technology

In structural design, with the introduction of thermal simulation technology has improved, the overall power density of the drive ensures the heat dissipation of the whole machine

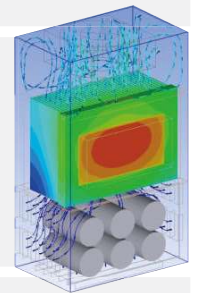

### 3. Easy Installation

Protruding treatment of mounting holes, It provides convenience for customers' installation.

### 4. Expansion Card Easy Installation

Customers can choose expansion cards according to their demand , It can be quickly installed to the reserved position of the Drive ; Compatible with a variety of cards, customers can choose according to their demand



## Outline and Installing Dimension

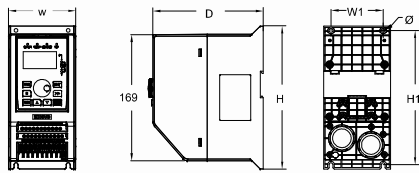

Outline Dimension			Installing Dimension		
H(mm)	W(mm)	D(mm)	H1(mm)	W1(mm)	Bore Diameter (mm)
0.7KW~4.0KW					
192	90	148	180	70	Ø5

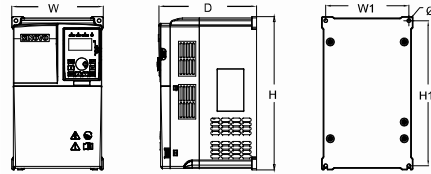

Outline Dimension			Installing Dimension		
H(mm)	W(mm)	D(mm)	H1(mm)	W1(mm)	Bore Diameter (mm)
5.5KW					
190	110	150	178	98	Ø5
7.5KW					
210	130	160	236	141	Ø5
11KW					
250	155	176	236	141	Ø5
15KW~18.5KW					
295	176	188	279	160	Ø7
22KW~30KW					
337	245	188	320	228	Ø7

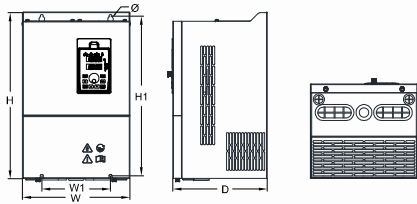

Outline Dimension			Installing Dimension		
H(mm)	W(mm)	D(mm)	H1(mm)	W1(mm)	Bore Diameter (mm)
37KW					
387	250	220	372	150	Ø7
45KW~55KW					
440	270	256	426	180	Ø7
75KW					
469	307	263	450	200	Ø10
90KW~110KW					
590	340	305	565	200	Ø10
132KW~185KW					
740	450	329	715	360	Ø12
200KW~250KW					
940	500	369	914	400	Ø12
280KW~350KW					
1045	725	390	1016	600	Ø14

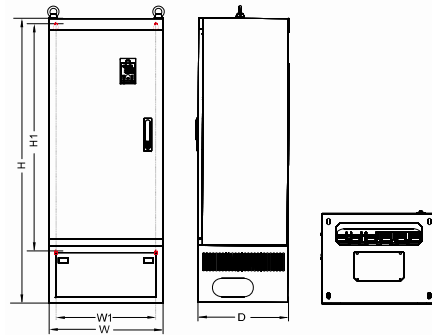

Outline Dimension			Installing Dimension		
H(mm)	W(mm)	D(mm)	H1(mm)	W1(mm)	Bore Diameter (mm)
400KW~500KW					
1810	850	405	1410	513	Ø14

## The Installing Dimension Size of the External Keypad (the maximum external length can reach 100 meters)

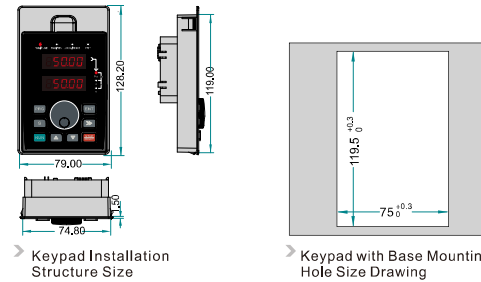

## Technical Data

Model	Power Capacity (kVA)	Input Current (A)	Output Current (A)	Adaptable Motor (kW)	Model	Power Capacity (kVA)	Input Current (A)	Output Current (A)	Adaptable Motor (kW)
SD600-2T : 0.7KW-2.2KW 1 phase 220V / 3 phase 220V					SD600-4T: 0.7KW -500KW 3 phase 380V 50/60Hz				
SD600-2T-0.7G	1.5	8.2/5.5	4.7	0.75	SD600-4T-30G	40	62.5	60	30
SD600-2T-1.5G	3.0	14.0/7.7	7.5	1.5	SD600-4T-37G	57	76	75	37
SD600-2T-2.2G	4.0	23.0/12.0	10.0	2.2	SD600-4T-45G	69	92	91	45
SD600-4T: 0.7KW-500KW 3 phase 380V SD600-4T: 50/60Hz					SD600-4T-55G	85	113	112	55
SD600-4T-0.7G	1.5	3.4	2.3	0.75	SD600-4T-75G	114	157	150	75
SD600-4T-1.5G	3.0	5.0	3.7	1.5	SD600-4T-90G	134	180	176	90
SD600-4T-2.2G	4.0	5.8	5.1	2.2	SD600-4T-110G	160	214	210	110
SD600-4T-4.0G	5.9	10.5	8.5	4.0	SD600-4T-132G	192	256	253	132
SD600-4T-5.5G	8.9	14.6	13	5.5	SD600-4T-160G	231	307	304	160
SD600-4T-7.5G	11	20.5	17	7.5	SD600-4T-185G	255	333	330	185
SD600-4T-11G	17	28	25	11	SD600-4T-200G	287	380	377	200
SD600-4T-15G	21	35	32	15	SD600-4T-220G	311	429	426	220
SD600-4T-18.5G	24	38.5	37	18.5	SD600-4T-250G	355	470	465	250
SD600-4T-22G	30	46.5	45	22	SD600-4T-280G	396	525	520	280
					SD600-4T-315G	439	605	600	315
					SD600-4T-350G	479	665	660	355
					SD600-4T-400G	530	730	725	400
					SD600-4T-450G	600	825	820	450
					SD600-4T-500G	660	900	900	500

# Basic Wiring Diagram

## Control Terminal Wiring Diagram

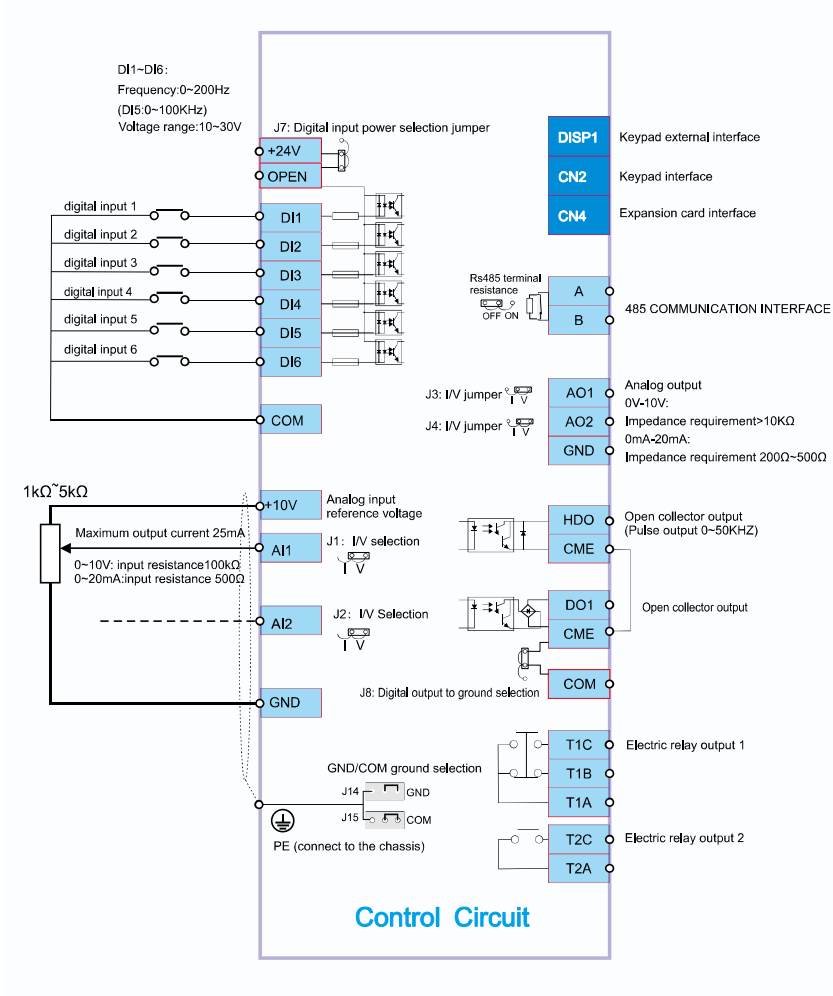

## Control Terminal Wiring Diagram

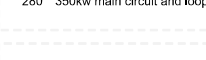
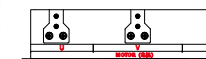
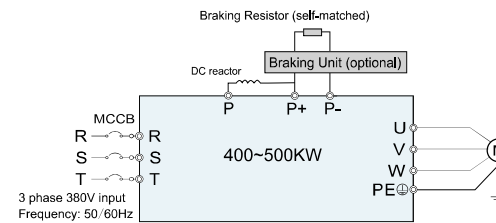
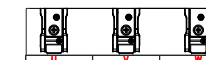
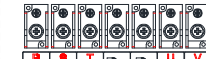
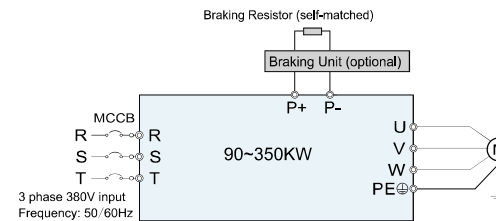
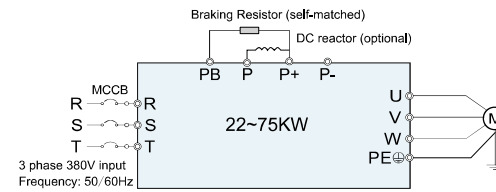
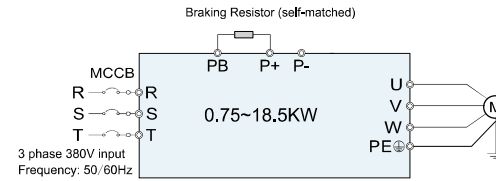

## Technical Specification

Items	Specification
Maximum Frequency	Vector control:0.00~500.00Hz; V/F control: 0.00~500.00Hz
Carrier frequency	0.5kHz~16kHz; the carrier frequency is automatically adjusted based on the load features.
Input frequency resolution	Digital setting 0.01Hz; Analog setting: Max frequency × 0.025%
Control Mode	V/F control: Open loop vector control (SVC) Closed loop vector control (FVC)
Start Torque	0.25Hz/150% (SVC); 0Hz/180% (FVC)
Speed range	1~200 (SVC); 1: 1000 (FVC)
Stable speed accuracy	±0.5% (SVC); ±0.02% (FVC)
Torque control accuracy	+ 5% (SVC)(5Hz above); +3% (FVC)
Overload capacity	G type: 150% rated current for 60s
Torque boost	Auto torque boost; Manual torque boost: 0.1%~30.0%
V/F control	4 ways: Line, multi-point Square V/F curve V/F separation
Accelerate/Decelerate curve	Line or S-curve Acc/Dec mode, four kinds of Acc/Dec time.; Ranges of Acc/Dec time is 0.0s~6500.0s
DC braking	DC braking frequency 0.00Hz~ Maximum frequency Braking current: 0.0%~100.0% (rated current) Braking 1000.0s
Jog control	Jog frequency range:0.00Hz Maximum frequency; Jog Accelerate time: 0.0s~6500.0s
Simple PLC、Multi-speed	Realize up to 16-speed operation through built-in PLC or control terminal
Inbuilt PID	It is convenient to realize the process control closed-loop control system
Auto voltage regulation(AVR)	When the grid voltage changes, it can automatically keep the output voltage constant
Overvoltage/over-current stall control	Automatically limit current and voltage during operation to prevent frequent over-current and-over voltage trips
Torque limit and control	The torque is automatically limited during operation to prevent frequent over-current trips; closed-loop vector mode can realize torque control
Non stop function	In case of instantaneous power failure, the load feedback energy is used to compensate for the voltage drop to keep the inverter running for a short time
Speed tracking start	Speed identification of the motor under high-speed rotation to achieve smooth start without impact
Rapid current limit	Fast software and hardware current limiting technology to avoid frequent over-current faults of the inverter
Virtual IO	Five virtual DO, five virtual DI, can realize simple logic control
Timing Control	Timing control function: setting time ranges - 0.0Min~6500.0Min
Multi-motor switch	Two groups of independent motor parameters can realize switching control of two motors
Bus support	One independent MODBUS communication, one CAN communication, one Profibus-DP
Multi-encoder support	Support differential, open-collector photoelectric encoder, resolver and other position sensors
Command Source	Operation panel setting, control terminal setting, serial communication port setting, Can be switched in many ways
Frequency source	10 kinds of frequency sources: no binding, digital setting, analog current setting (AI1/AI2), pulse setting (DI5), Multi-speed, simple PLC, PID, communication setting; Can be switched in many ways
Auxiliary Frequency source	10 kinds of auxiliary frequency sources, Flexible realization of auxiliary frequency fine-tuning and frequency synthesis
Input terminal	Standard configuration: 6 digital input terminals, one of which supports high speed pulse input; 2 analog input terminals, Expansion capacity: 4 digital input terminals; 1 analog input terminal.
Output terminal	Standard configuration: 1 high speed pulse output terminal; 1 digital output terminal; 2 relay output terminals; 2 analog output terminals. Expansion capacity: 1 relay output terminal; 1 analog output terminal.
LED display	Double LED display keyboard, more convenient to monitor parameters
LCD display	Optional, Chinese/English/Russian display function parameters and status information
Specification Copy	The parameters can be quickly copied through the standard operation panel and optional LCD
The key lock and function selection	Realize partial or full lock of keys, define the scope of action of some keys, to prevent misoperation operation panel options
Protection Function	Motor to ground short circuit detection, input and output phase loss protection, overcurrent protection, overvoltage protection, undervoltage protection, overheating protection, Overload protection, etc.
Accessories	Brake components, simple IO expansion card, multi-function IO expansion card, CAN communication expansion card, differential input PG card, Resolver PG card



# Application SINOVO

