



# SINOVO

## SINO SOFT 30 SOFT STARTER



### SHENZHEN SINOVO ELECTRIC TECHNOLOGY CO.,LTD

Add:5th Floor, No. D Building, Huafeng International Robot Industry Park, Xixiang Street, Hangcheng Road, Baoan District, Shenzhen City

Tel: (0755)29784870

Fax: (0755)29784969

Tech support: 400-881-8689

<http://www.sinovo-vfd.com>

400-8818-689





## COMPANY PROFILE

SINOVO, established in 2006, is committed to be globally leading provider for products and service of industrial automation and new energy. We are specialized in the products of AC Drive, Electric vehicle motor controller, Solar Inverter, Servo and soft starter, etc, which are widely used in machine tools, textiles, packaging, printing, plastics, paper making, pharmaceuticals, oil field, chemicals, elevator, crane, cables, ceramics, building automation, Fans & Water pumps, vehicles, rail traction and other fields.

SINOVO has set up more than 30 offices domestically and internationally including 200 employees, and one-third of them are R&D professionals. With 10 years of developing and marketing a consolidated sales and after-sales service network has been established nation widely which can provide customers with solutions, technological training and specialized support and now we are ready to bring our professional products and service to the international market.

SINOVO has received more than 10 fiscal incentives and policy support in energy saving and environment protection, technology development and advanced manufacturing from Shenzhen Municipal Government and also Baoan administrative District over the years by the virtue of leading capacity of independent innovation, and also registered more than thirty invention patents, utility model patents, appearance patents, and Software copyright patents in SIPO (State Intellectual Property Office). We've passed ISO9001 : 2008 quality management system certification , CE certification, awarded the National Innovation Fund , Shenzhen High-tech research subsidies, product Innovation Award and so on. "Innovation" is the soul we strive for, "Customer first, honesty and integrity, hand in hand advance together, win-win cooperation" is the business philosophy we stick in, we are destined to improve ourselves, to serve customers, to contribute society, to build a better earth with our technology strength.



## CONTENTS

Product Features.....	01
Naming Rules .....	02
Technical Specifications.....	02
Wiring Terminal.....	03
Installation requirements .....	03
Outline and installation dimension.....	04
Basic wiring diagram .....	06
External terminal.....	07
Main circuit wiring diagram .....	08
Operation Panel.....	08

## Product Features



### PERFECT HUMANIZED DESIGN

- » Perfect appearance and reasonable structure
- » Integrated functions and convenient operation
- » Solid reliable and compact structure
- » Excellent artistic design .

### RELIABLE QUALITY

- » Using computer simulation design;
- » SMT technical process;
- » Excellent electromagnetic compatibility;
- » high-temperature aging, vibration test.

### PERFECT AND RELIABLE PROTECTION

- » Novoltage, undervoltage , overvoltage protection ;
- » Overheating, start-up time is too long protection;
- » Input/output loss, three-phase imbalance protection ;
- » Overcurrent, overload, load short circuit protection.

### PROPRIETARY PRODUCTS

- » Appearance design patent
- » Software copyright patent
- » Proprietary motor starting and protection technology
- » Quick and thoughtful service

### UNIQUE TO DETECT EBUG EQUIPMENT AND PROCESS

- » Reliable performance and quality
- » Provide excellent supporting design;
- » Timely and thoughtful consultants;
- » Constantly improve the product performance according to user's opinion

## Naming rules

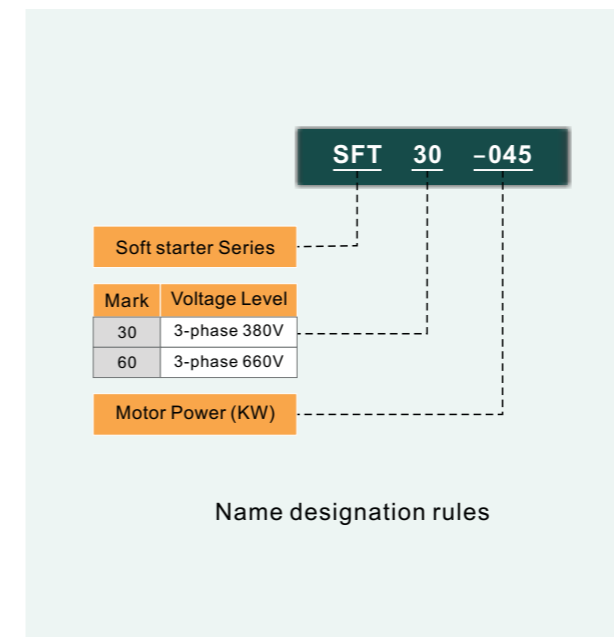

Name designation rules



Nameplate

## Technical Specifications

Item	Description
Three-phase power voltage (VAC)	380V/660V±15%
Frequency	50Hz
Adaptable motor	Squirrel-cage three-phase asynchronous motor
Starter frequency	Depending on the load suggest no more than 20 times per hour
Protection level	IP20 (Support agreement)
Anti-impact	15g/11ms
Seismic capacity	Below 3000 m above the ground, Vibration power plant under 0.5 G
Ambient / Operating Temperature	0~+40℃ without derating ( Between +40℃~60℃ , increased by 1 ℃, current reduced by 1.2% )
Storage temperature	-25℃~40℃
Humidity	Less than 90% without condensation or drop of water
Max operation height	Within 1000 m without derating ( above 1000m, increased by 100m, current reduced by 0.5% )
Cooling way	Natural air cooling
Max. operation angle relative to vertical installation location	Without request

### Wiring Terminal

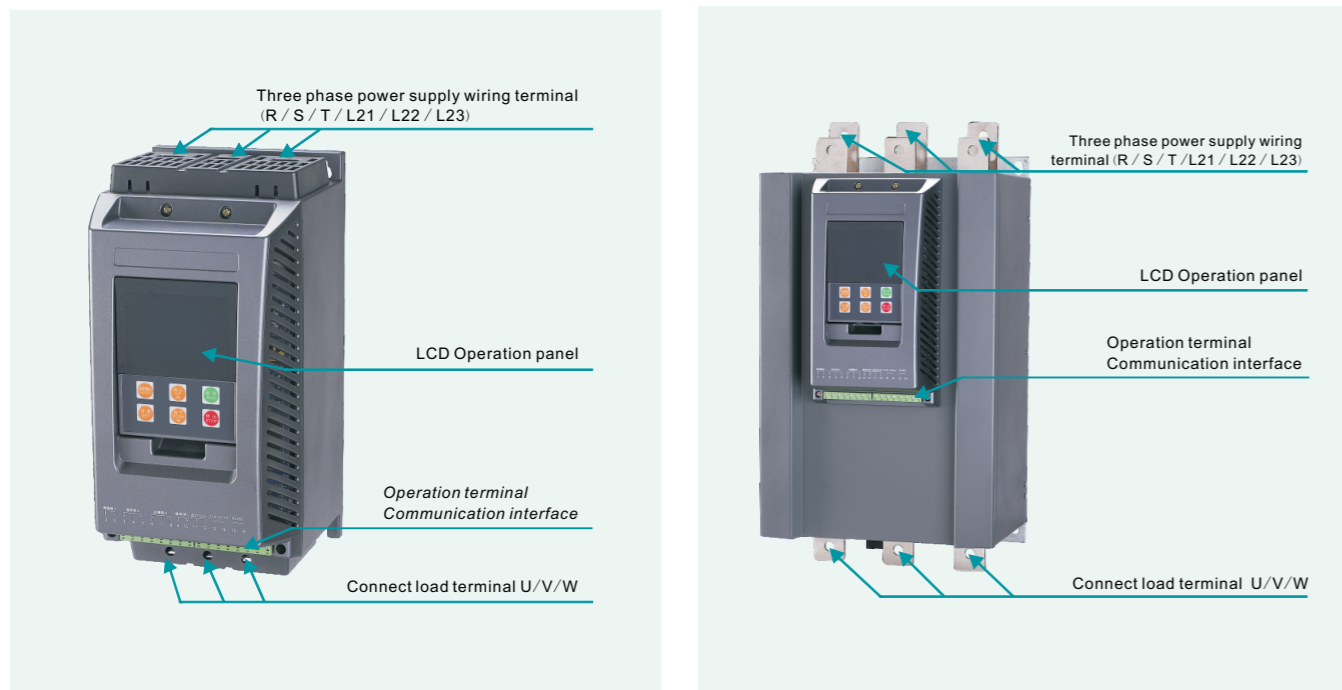

### Installation requirements

- » In order to ensure the soft starter has good ventilation and cooling conditions, the soft starter shall be installed vertically, as shown in the figure. When the soft starter cabinet installation, you must choose ventilated cabinet.

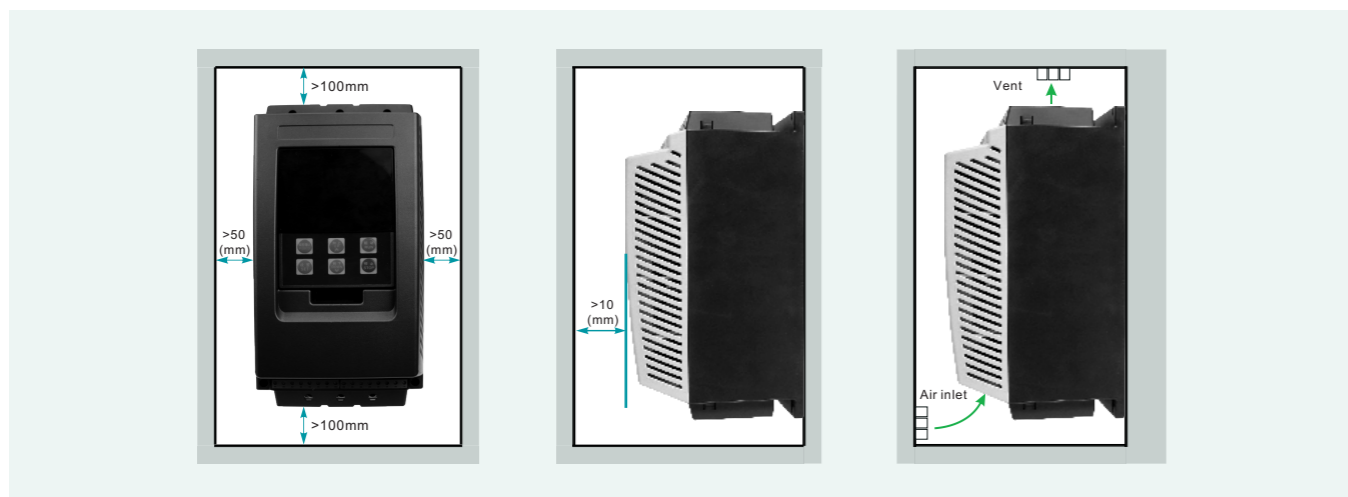

### Outline and installation dimension

#### 01 5.5KW-75KW Installation Dimension

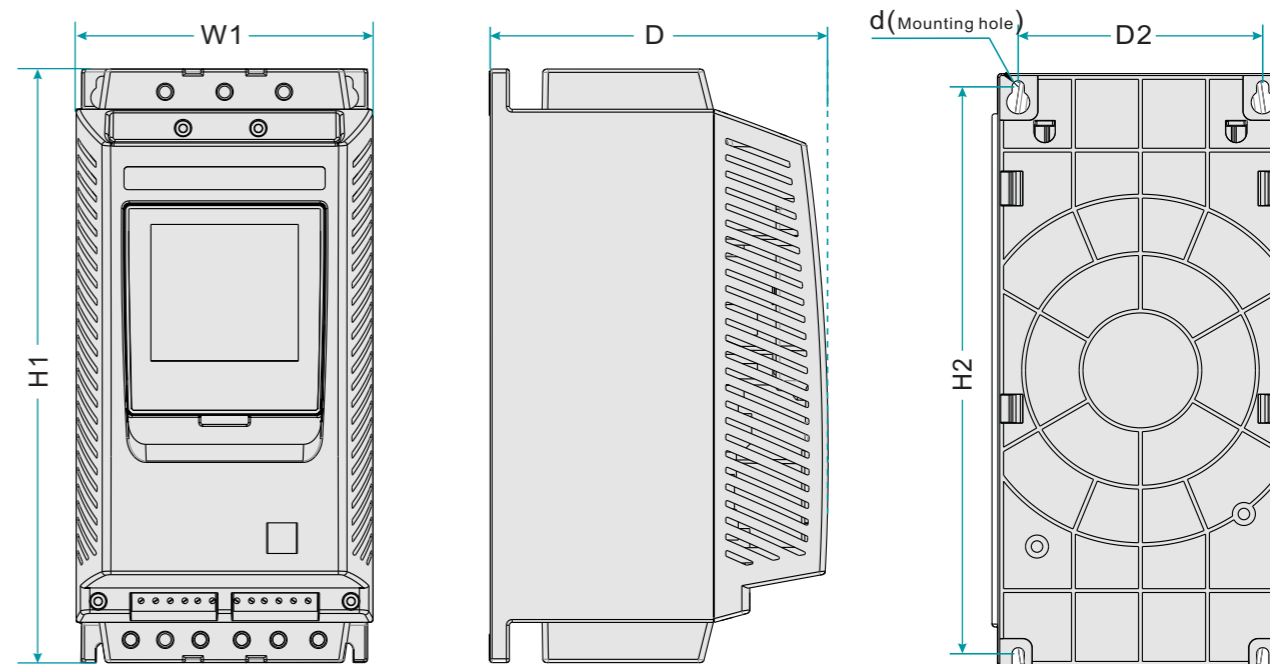

Model	Rate power (KW)	Rate current (A)	Outline dimension			Installation dimension			NW(kg)
			H1(mm)	W1(mm)	D(mm)	H2(mm)	W2(mm)	d(mm)	
SFT30-5.5	5.5	11	310	155	175	296	127	M6	<5
SFT30-7.5	7.5	15	310	155	175	296	127	M6	<5
SFT30-011	11	23	310	155	175	296	127	M6	<5
SFT30-015	15	30	310	155	175	296	127	M6	<5
SFT30-018.5	18.5	37	310	155	175	296	127	M6	<5
SFT30-022	22	43	310	155	175	296	127	M6	<5
SFT30-030	30	60	310	155	175	296	127	M6	<5
SFT30-037	37	75	310	155	175	296	127	M6	<5
SFT30-045	45	90	310	155	175	296	127	M6	<5
SFT30-055	55	110	310	155	175	296	127	M6	<5

- » Rated power and rated current refer to the maximum rating of the soft starter. Under normal circumstances, the adaptation of the motor relevant parameters should be less than this value

**Outline and installation dimension**

**02 75KW-600KW Installation Dimension**

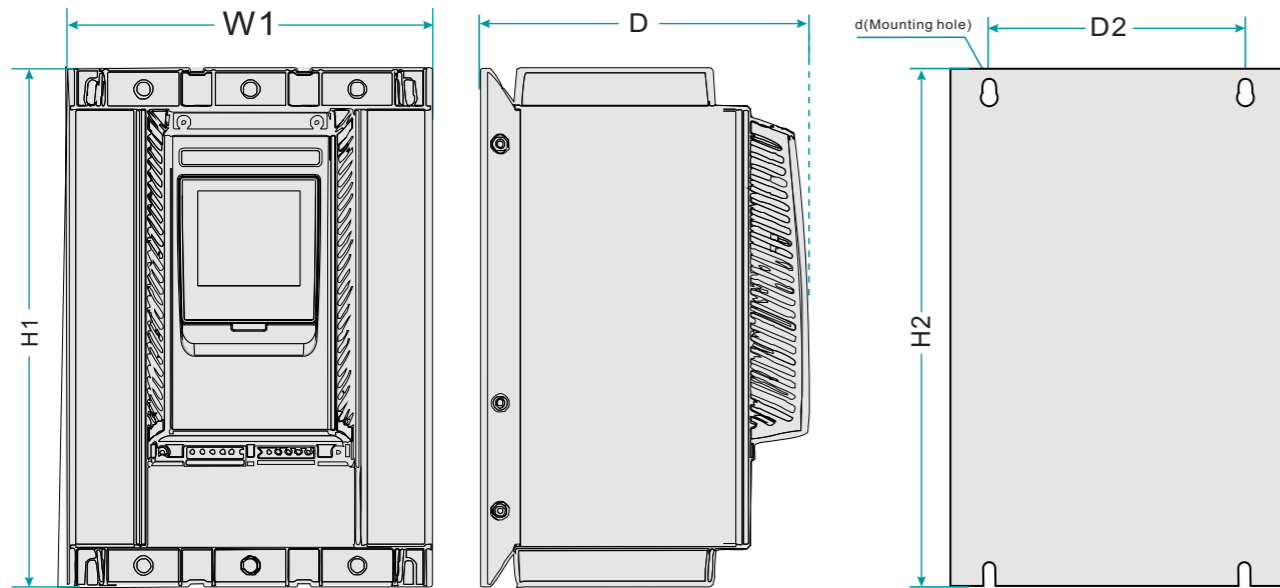

Model	Rate power (KW)	Rate current (A)	Outline dimension			Installation dimension			NW(kg)
			H1(mm)	W1(mm)	D(mm)	H2(mm)	W2(mm)	d(mm)	
SFT30-075	75	150	525	155	175	296	127	M6	<18
SFT30-090	90	180	525	155	175	296	127	M6	<18
SFT30-110	110	230	525	155	175	296	127	M6	<18
SFT30-132	132	264	525	155	175	296	127	M6	<18
SFT30-160	160	320	525	155	175	296	127	M6	<18
SFT30-185	185	370	525	155	175	296	127	M6	<18
SFT30-200	200	400	525	155	175	296	127	M6	<18
SFT30-250	250	500	560	290	250	460	260	M10	<23
SFT30-280	280	560	560	290	250	460	260	M10	<23
SFT30-320	320	630	560	290	250	460	260	M10	<23

» Rated power and rated current refer to the maximum rating of the soft starter. Under normal circumstances, the adaptation of the motor relevant parameters should be less than this value.

**Basic wiring diagram**

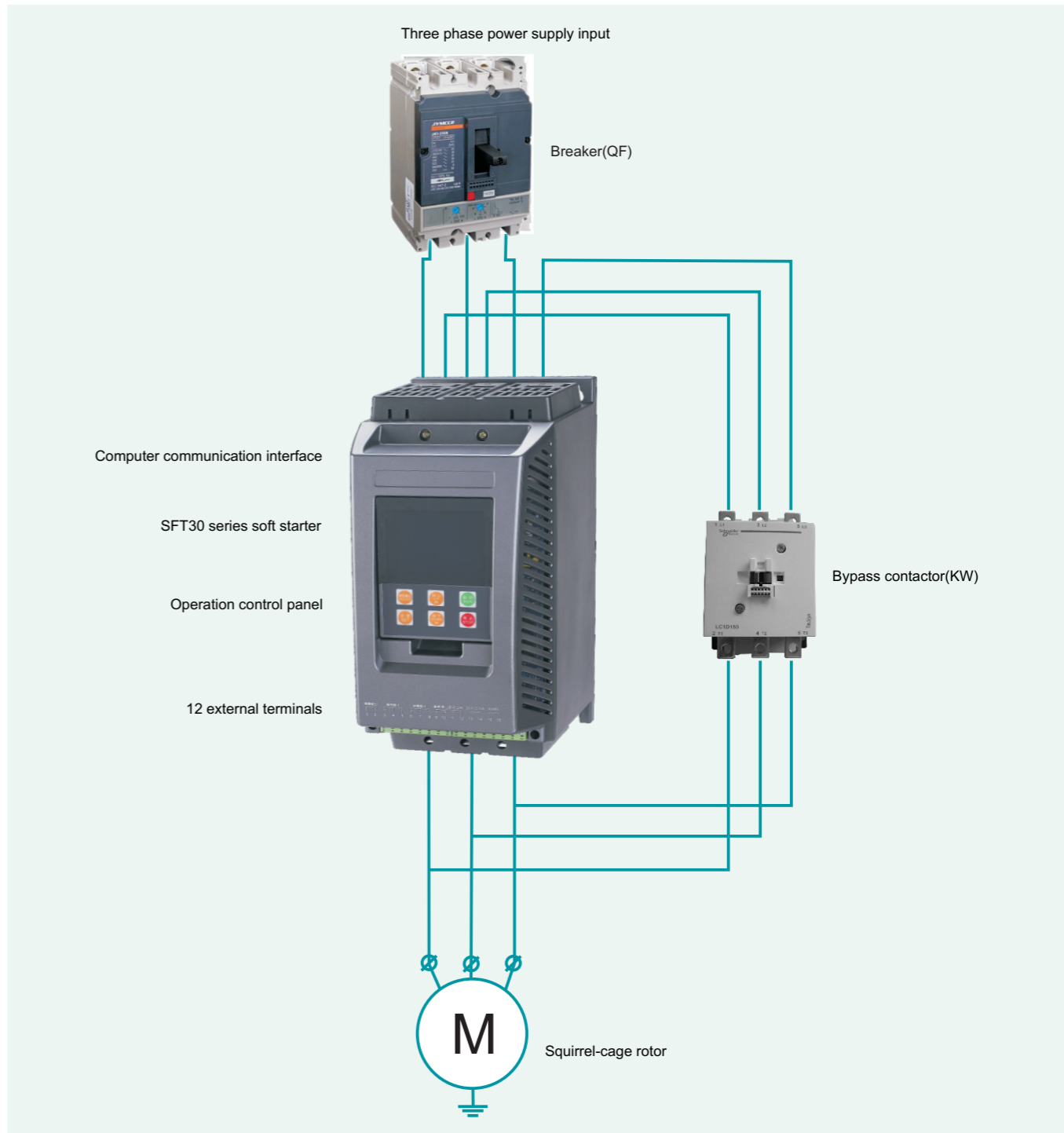

» Note: In the six input copper bar, the top three copper bar connect breaker, and following three copper bar connect bypass contactor.

**External terminal**

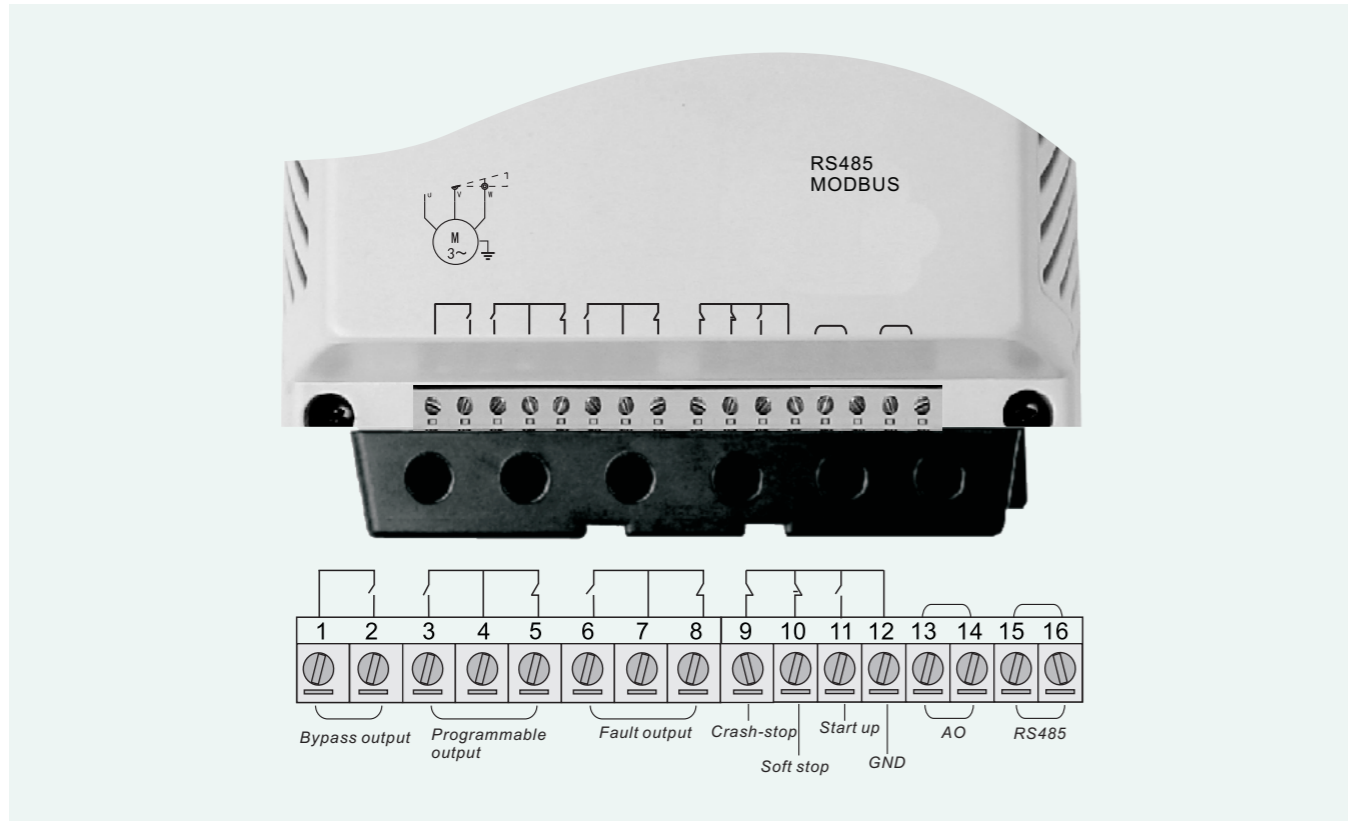

Terminal mark	Description
L1、L2	Control power supply AC380V(Power supply interface lie in the left side of the upper cover of the soft starter)
01、02	Bypass output(Built-in bypass)
03	Programmable relay output 1
04	Programmable relay output 2
05	Programmable relay output 3
06	Fault relay output 1
07	Fault relay output 2
08	Fault relay output 3
09	Crash-stop input
10	Soft stop input
11	Start up input
12	GND
13	AO 1, DC 4~20MA (0~20MA please contact factory before pre-order)
14	AO 2
15	Communication input/output B
16	Communication input/output A

**MainCircuit Wiring Diagram**

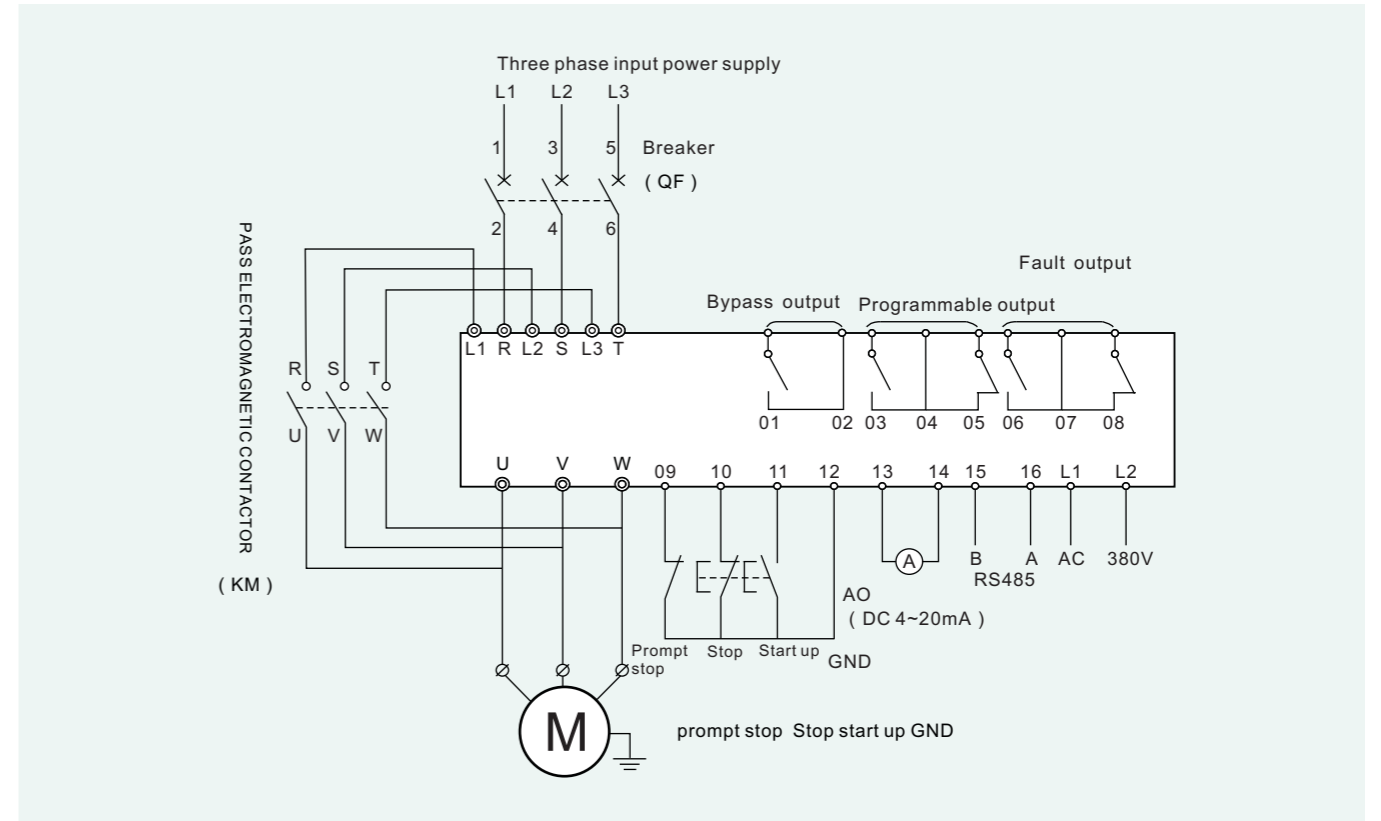

**Operation Panel**

