

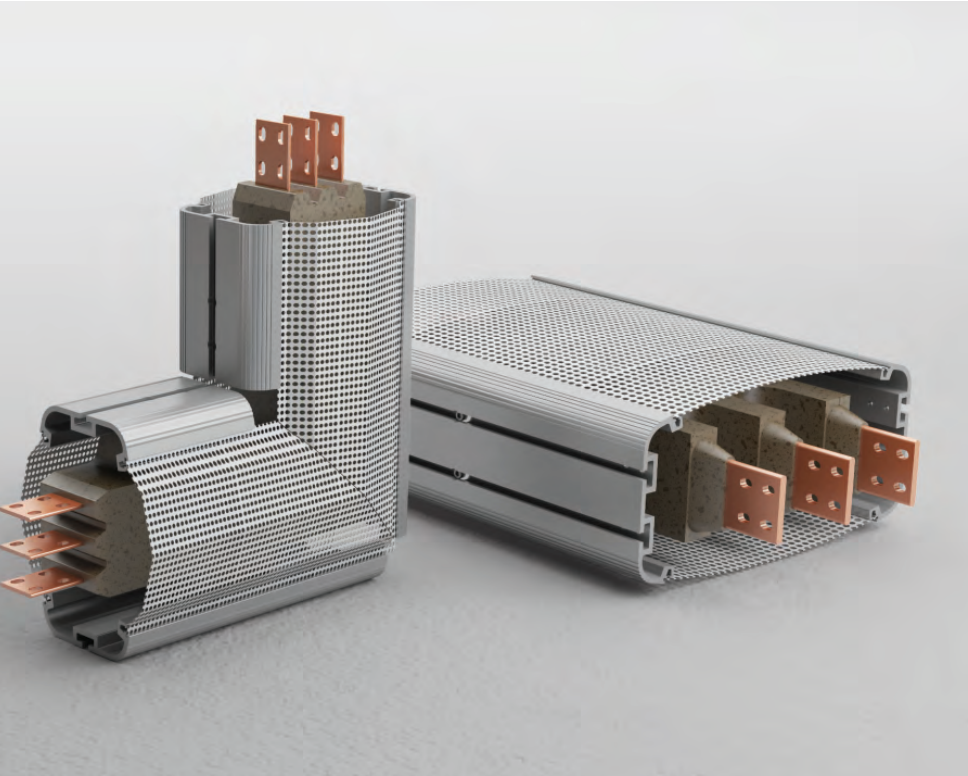

E-LINEMV

MANUAL



E-LINEMV





CONTENTS

Introducion	2
Unloading, Handling and Storage of Products	3
Joint Area General Information	3
Handling and Lifting	4-5
Horizontal & Vertical Medium Voltage Busbar Applications	6
Equipment Used	7
12 kV Horizontal Mounting Application	8
12 kV Vertical Mounting Application	9
Horizontal & Vertical Medium Voltage Busbar Applications	10
24 kV Horizontal Mounting Application	11
24 kV Vertical Mounting Application	12
Resin Application Horizontal During Assembly	13
Resin Application Vertical During Assembly	14
Preparation of Joint Casting Material	15
12 kV Product Overview	16-17
24 kV Product Overview	18-19
Certificates	20

Dear Customer,

EAE Elektrik A.S. Products are designed to provide the maximum benefit in efficiency and service. Our products are manufactured in accordance with IEC standards and EAE is quality assured to ISO 9001 standards in their modern production plants in Istanbul .

The components that you have purchased are manufactured by a completely environment conscious, that is ISO 14001 certified.

These instructions should be read carefully and acted upon before taking delivery of equipment on site.

Handling, installation and operation of busbar systems should be carried out only by skilled, trained and authorized personnel using all associated equipment such as rubber gloves, helmet, safety glasses or face shields and flash resistant clothing in accordance with established safety practices.

The busbar system's successful operation depends on correct handling, installation, operation and maintenance. Improper installation may cause personal injury and the failure of the busbar system and damage to other property.



Unloading:

- Forklift is the most reliable and easiest method for the unloading of the products from the container or the truck arriving at the worksite.
- Utmost care is required to be exercised to ensure avoidance of any harm that can be sustained by the products during the unloading process.

Storage:

- From the packing list check the number of pallets received, the number, dimensions and the condition of the busbar lengths. Advise any discrepancies immediately to the local EAE representative.
- All products should be stored in a dry environment. The casting materials for the joint must be stored at a temperature between 5 °C and 25 °C and not exposed to direct sunlight

Handling:

- Do not handle the materials using steel ropes or hooks. As shown in the castresin busbar should be lifted using lifting straps placed at each end of the busbar length.
- Short modules may be lifted using a single strap providing that the piece is balanced.
- A wooden spacer should be used every 1.5m when storing the lengths placed on top of each other.
- Do not stack more than 2 modules on each other horizontally.

► Joint Area General Information

Joint Area Processing and Casting:

- Wait for a while before process.
- For vertical applications the mould sides should be tightened or supported to prevent the mould slipping down.
- The expiry dates of the resin and hardener should be checked. They should not be used if the expiry date has passed.
- Ensure that the sand additive is dry.
- The mixture should be stirred for at least 5 minutes until thoroughly mixed.
- The mixture should be poured into the joint to the top of the mould, it should not be allowed to overflow.
- Inside of the joint mould material shall be cleaned with a cloth; do not use a solvent or a metal cutting tool.

Pre-Cast Controlling of Juncture Area:

- The exposed conductor parts of the busbar must be checked for any dampness due to the coldness
- The exposed conductor parts of the busbar must be checked for any dust etc.
- The position of the busbar must be checked before starting the installation
- Make sure that all the nut bolts in the attachment plate are torqued with 72 Nm.
- Joint moulds must be joined so that there are no openings.

Strapping type ropes should only be used instead of round ropes to prevent the materials slipping during handling.

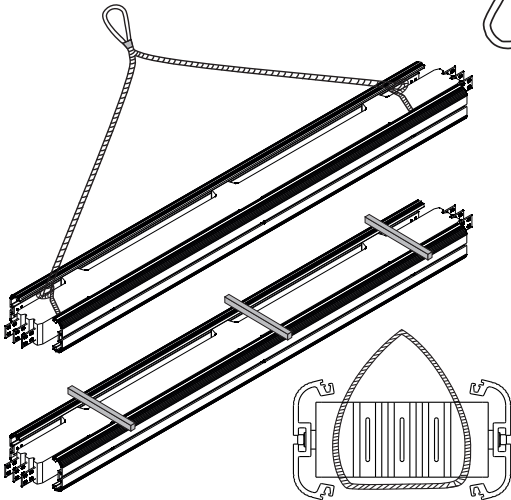
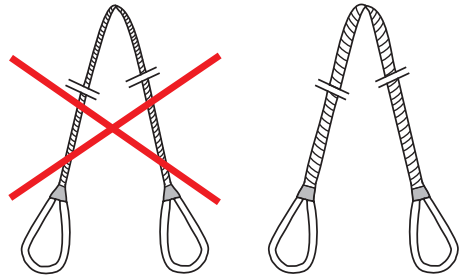

Short modules can be handled by a single rope, however, ensure that it is balanced.

A wooden wedge shall be used every 1.5 m when the materials are placed on each other while storing them.

Do not put more than 2 modules on each other horizontally.

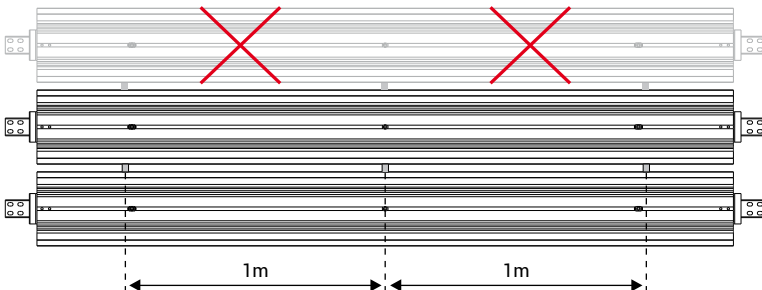

Introduction:

This installation manual includes the details of safe and quick handling and installation of cast resin busbar product. It shall be read carefully before starting the procedures on the product and relevant steps shall be followed.

Things To Do:

1. Read the info note on the pallet; lift and handle the the product as shown in "Figure 1" taking the pallet weight into consideration.
2. Product shall be hanged and lifted as shown in "Figure 2" while it is handled.
3. Resin and hardener shall be stored as shown in Figure 3.
4. Busbar route shall be marked before starting the installation.
5. Installation shall start from a single point (preferably panel) and shall be completed with the last 6. module.
7. Do not perform casting before performing megger test on the joint and observing infinite resistance as the result of the test.
8. Do not apply expired joint casting agent.

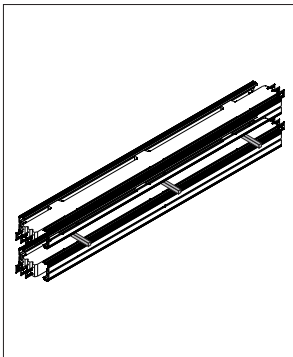

Figure 1

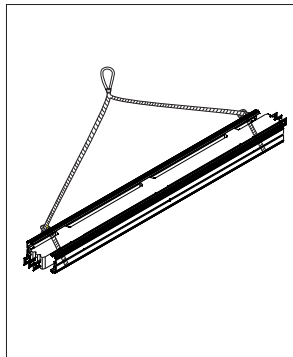

Figure 2

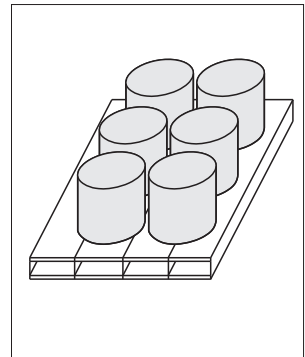

Figure 3

FIGURE 1 - EDGEWISE APPLICATION

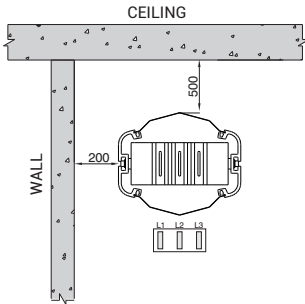
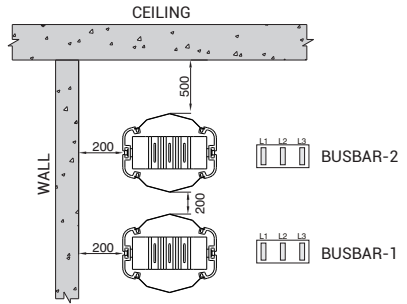

FIGURE 2 - EDGEWISE APPLICATION



Primarily on the installation phase;
Busbar-1 line should be installed before Busbar-2 line.

FIGURE 3 - CROSSING UNDER A BEAM ON EDGEWISE APPLICATION

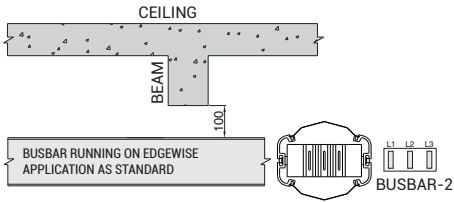

FIGURE 4 - SAMPLE WALL CROSSING WITH FIRE BARRIER

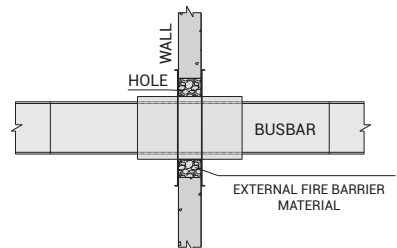
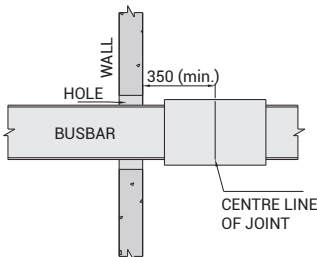
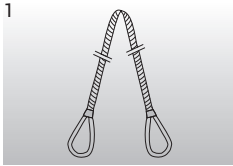

FIGURE 5 - STANDARD WALL CROSSING



Attention !

- For correct installation, the dimension from the busbar to the ceiling should not be less than 500mm
- The joint should be not come across to Beams.
- The dimensions given above are minimum values.
- All dimensions are given in mm.



Fabric Crane Ropes

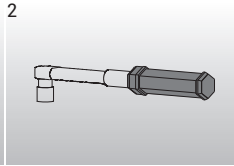

Torque Wrench

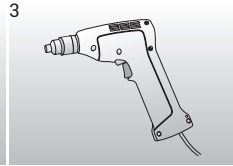

Hot Air Blower

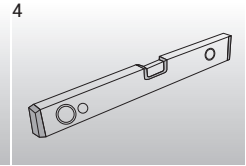

Spirit Level

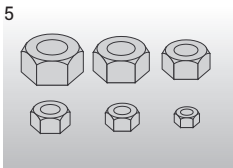

Nut Set

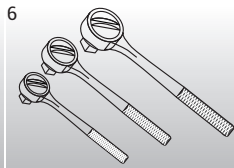

Socket Set

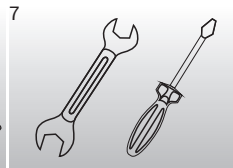

Wrench, Screwdriver



Lifting Device
(forklift truck, crane, hoist etc.)

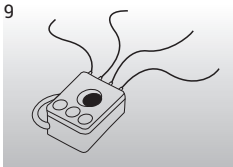

Megger Device

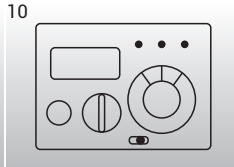

Dielectric Test Device
5 kV DC

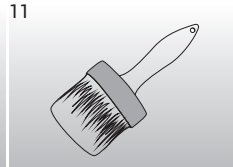

Paint Brush



Scaffold



Mixer

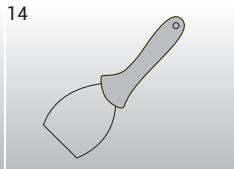

Putty knife

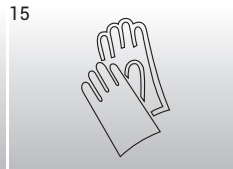

Protective Clothes,
Gloves, Goggles

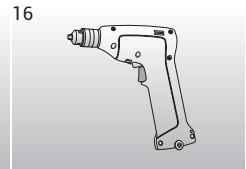

Drill

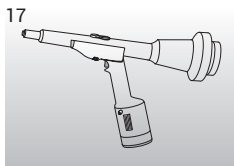

Rivet Tool

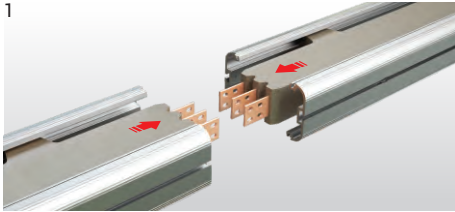

The ends of the conductors of the busbars are cleaned with a clean dry cloth. The busbars have to be fixed in the same axis, with a max. distance of 10 mm between the two conductors.

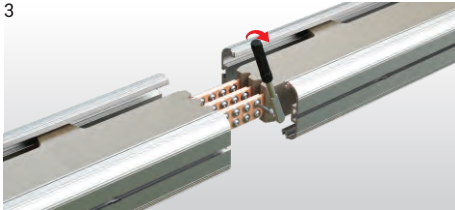

All bolts must be tightened to 72 Nm with torque wrench.

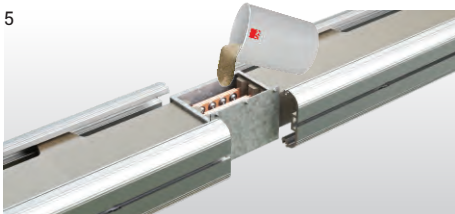

The prepared for casting should be cast from the same spot at all times.

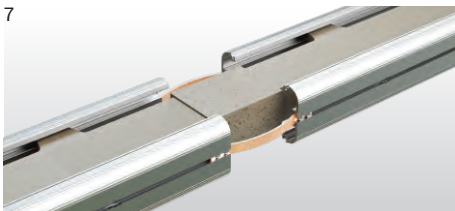

After the curing of the cast material is completed the sheet metal moulds can be removed. (Reaction is completed within 8 - 24 hours based on the air temperature.)The flexibles are fitted to the profiles grooves for earth continuity.

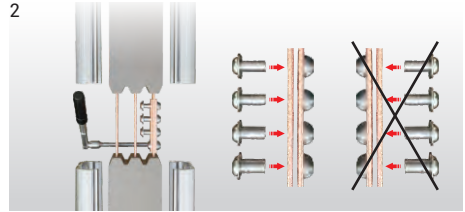

As shown on the figure, junction plates fixed as the bolts face the same direction at all times.

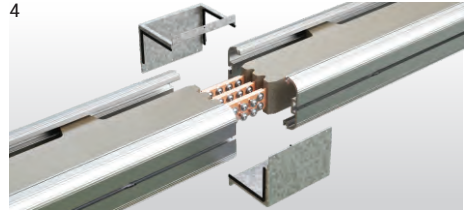

Before assembling the casting moulds, inner surfaces of casting moulds have to be wiped with clean dry cloth.

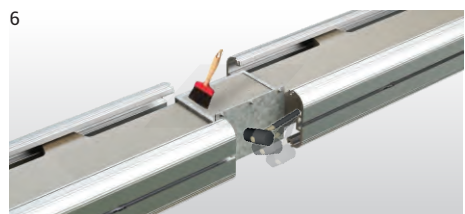

The material should be 'vibrated' with the help of a plastic hammer to remove the air in the material. Then the air bubbles on the surface have to be brushed.

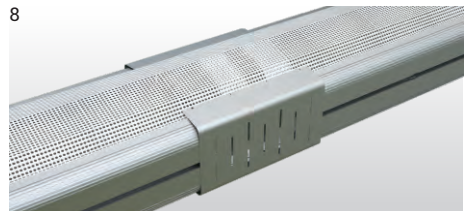

Joint protection pieces of perforated aluminium should be fitted.

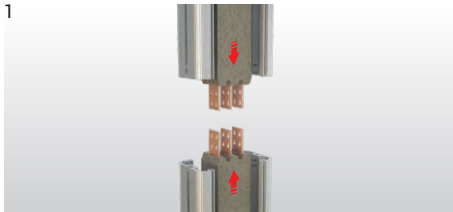

The ends of the conductors of the busbars are cleaned with a clean dry cloth. The busbars have to be fixed in the same axis, with a max. distance of 10 mm between the two conductors.

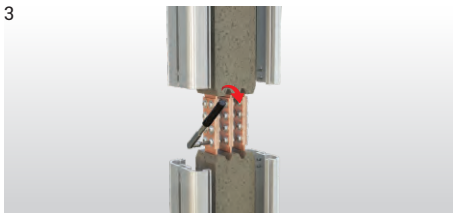

All bolts must be tightened to 72 Nm with torque wrench.



The prepared for casting should be cast from the same spot at all times.

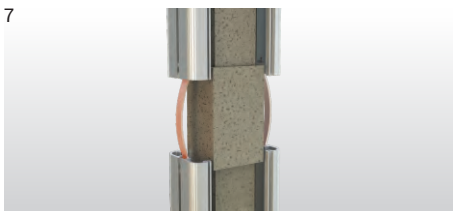

After the curing of the cast material is complete the sheet metal moulds can be removed. (Reaction is completed within 8 - 24 hours based on the air temperature.) The flexibles are fitted to the profiles grooves for earth continuity.

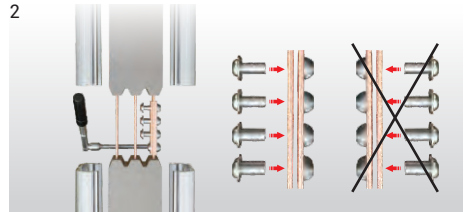

As shown on the figure, junction plates fixed as the bolts face the same direction at all times.

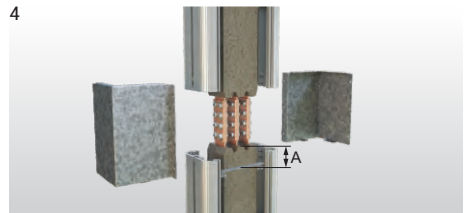

Support sheets are secured on the lower part of juncture area by stem bar. A min. 50-60 mm. The joint moulds are affixed on the support sheet by cleaning with a dry and clean piece of cloth.

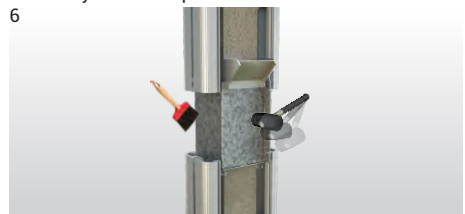

The material should be "vibrated" with the help of a plastic hammer to remove the air in the material. Then the air bubbles on the surface have to be brushed.

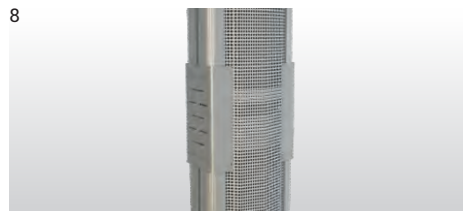

Joint protection pieces of perforated aluminium should be fitted.

FIGURE 1 - EDGEWISE APPLICATION

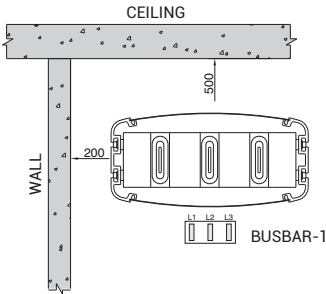
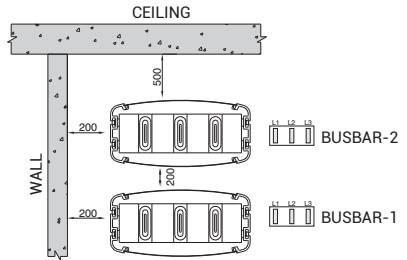

FIGURE 2 - EDGEWISE APPLICATION



Primarily on the installation phase; Busbar-1 line should be installed before Busbar-2 line.

FIGURE 3 - CROSSING UNDER A BEAM ON EDGEWISE APPLICATION

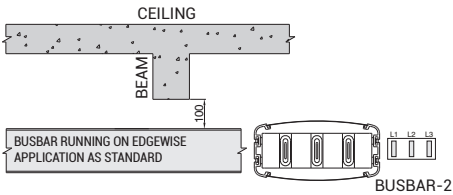

FIGURE 4 - SAMPLE WALL CROSSING WITH FIRE BARRIER

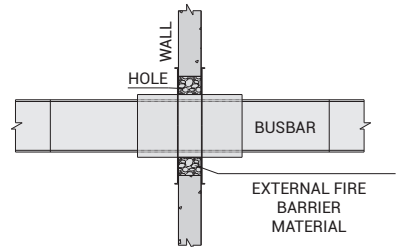
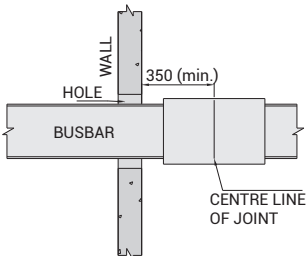

FIGURE 5 - STANDARD WALL CROSSING



⚠ Attention !

- For correct installation, the dimension from the busbar to the ceiling should not be less than 500mm
- The joint should be not come across to Beams.
- The dimensions given above are minimum values.
- All dimensions are given in mm.

MV MANUAL

►► Horizontal Mounting Application

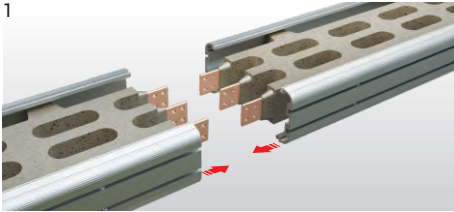

1

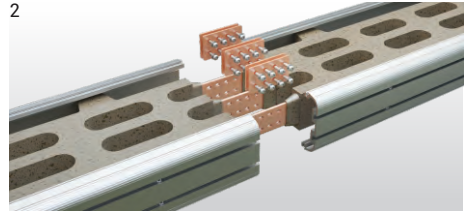

2

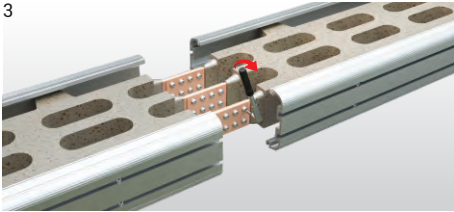

3

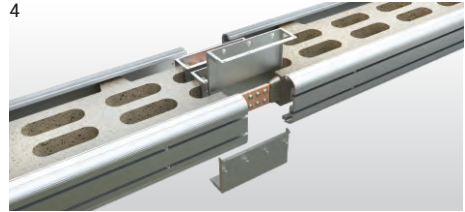

4

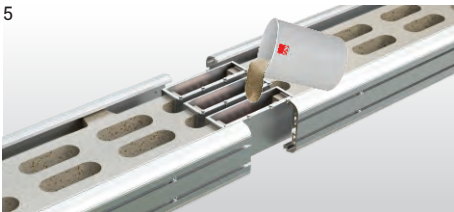

5

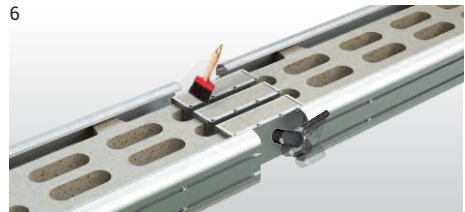

6

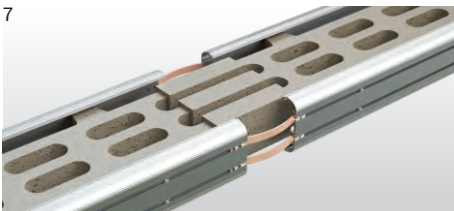

7

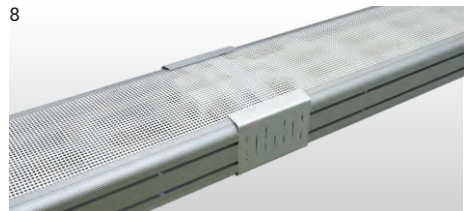

8

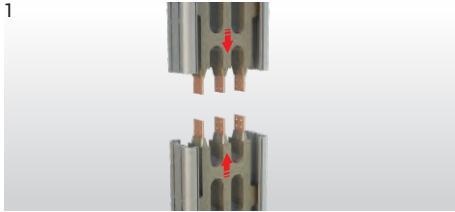

The ends of the conductors of the be busbars are cleaned with a clean dry cloth. The busbars have to be fixed in the same axis, with a max. distance of 10 mm between the two conductors.

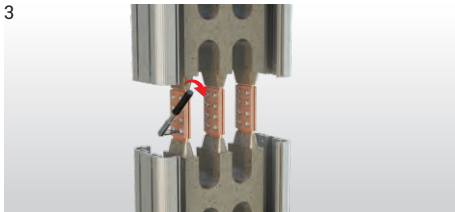

All bolts must be tightened to 72 Nm with torque wrench.

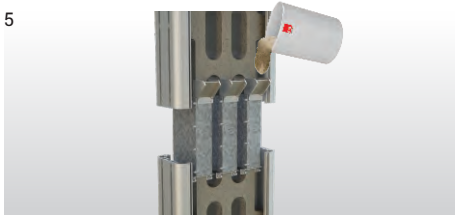

The prepared for casting should be cast from the same spot at all times.

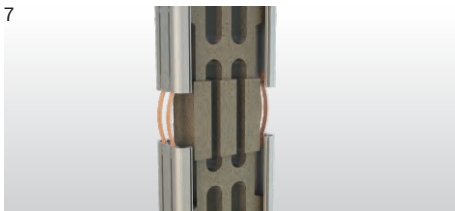

After the curing of the cast material is complete the sheet metal moulds can be removed. (Reaction is completed within 8 - 24 hours based on the air temperature.) The flexibles are fitted to the profiles grooves for earth continuity.

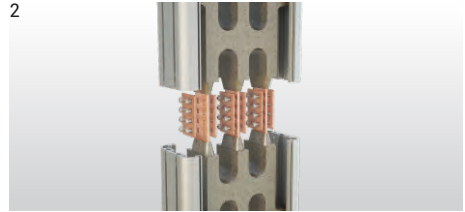

As shown on the figure, junction plates shall be fixed as the bolts face the same direction at all times.

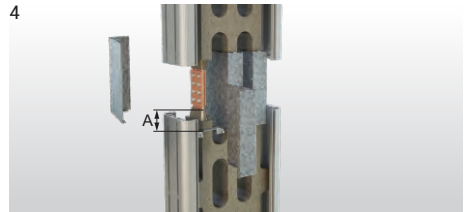

Support sheets are secured on the lower part of juncture area by stem bar. A min. 50-60 mm. The joint moulds are affixed on the support sheet by cleaning with a dry and clean piece of cloth.



The material should be 'vibrated' with the help of a plastic hammer to remove the air in the material. Then the air bubbles on the surface have to be brushed.

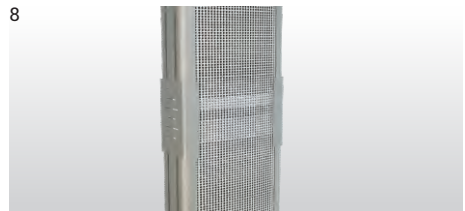

Joint protection pieces of perforated aluminium should be fitted.

► Horizontal Application

After the entire adjustments are made, megger test and dielectric test shall be conducted on the busbar system coupled and absence of any stray voltage shall be ensured accordingly. Material prepared in buckets shall be casted on juncture area. Material casting shall be ensured not to have any clearance at all. After the completion of casting process, the material shall be ensured to be placed tightly by slightly hammering the block joint moulds.

- After the block joint mould is filled up to the upper level, the surface is required to be levelled out with a brush.
- For the purpose of expediting the air outlet after the completion of the casting process, vibration rendering process shall be applied on the mold for 8-10 minutes by a plastic hammer.
- Casting surface shall be brushed once in every 10-15 minutes and air bubbles forming shall be removed and the surface shall be smoothed accordingly.
- To remove the juncture mold, it shall be waited for curing process of 8-24 hours and the complete stiffening to be completed.
- In case of a requirement of more than 1 dose of application in the application of the junctureresin, it shall be performed successively without waiting for the application of the 2nd and the 3rd doses.

Note: Material for each joint shall be prepared separately and this prepared material shall be poured within 15 minutes.

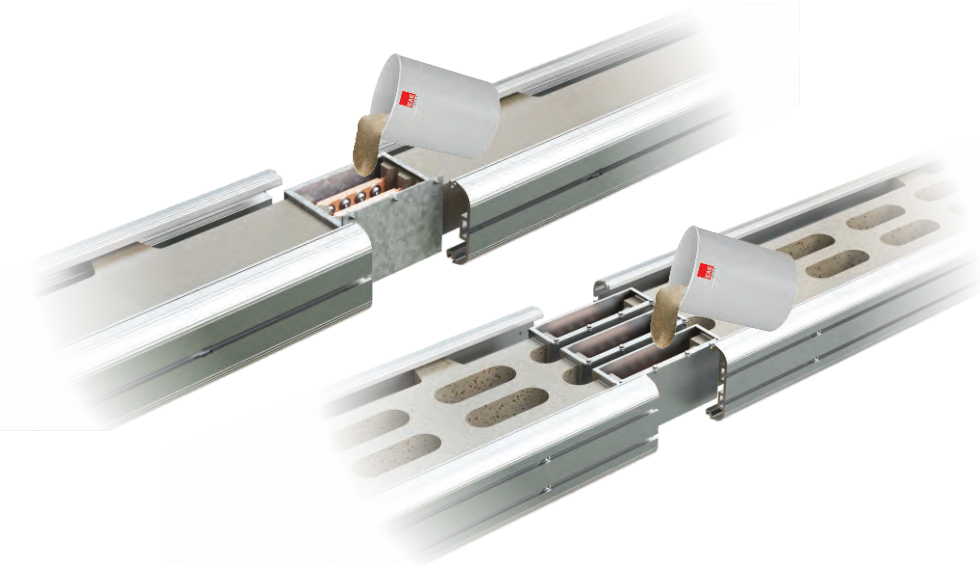

▶ Vertical Application

After the entire adjustments are made, megger test and dielectric test shall be conducted on the busbar system coupled and absence of any stray voltage shall be ensured accordingly. Material prepared in buckets shall be casted on juncture area. Material casting shall be ensured not to have any clearance at all. After the completion of casting process, the material shall be ensured to be placed tightly by slightly hammering the block joint moulds.

- After the block joint mould is filled up to the upper level, the surface is required to be levelled out with a brush.
- For the purpose of expediting the air outlet after the completion of the casting process, vibration rendering process shall be applied on the mold for 8-10 minutes by a plastic hammer.
- Casting surface shall be brushed once in every 10-15 minutes and air bubbles forming shall be removed and the surface shall be smoothed accordingly.
- To remove the block joint mould, it shall be waited for curing process of 8-24 hours and the complete stiffening to be completed.
- In case of a requirement of more than 1 dose of application in the application of the juncture resin, it shall be performed successively without waiting for the application of the 2nd and the 3rd doses.

Note: Utmost care should be exercised for the alignments in vertical applications. Otherwise, clearances may form on the upper part to risk the juncture accordingly.

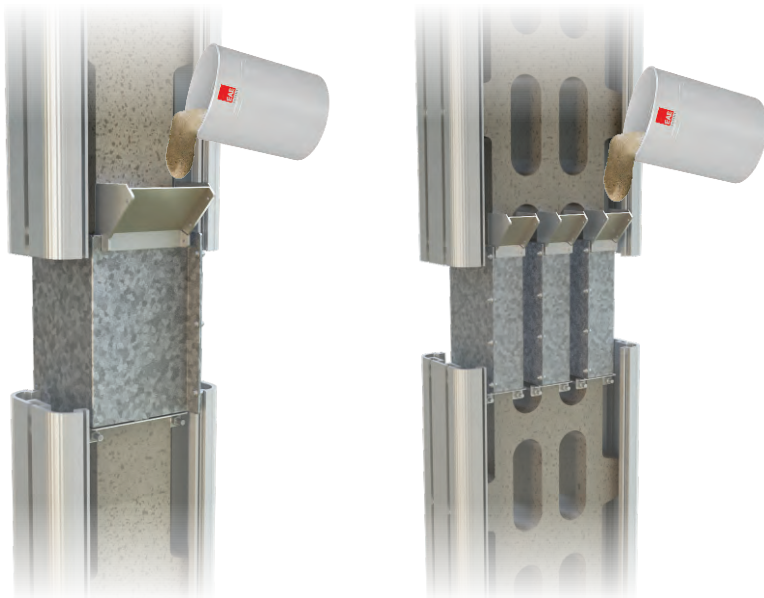

MV MANUAL

►► Preparation of Joint Casting Material



Megger test is definitely required to be conducted prior to the casting process.

Resin (A), Hardener (B) and fillers; must be stored at least one day over ($> 20\text{ }^{\circ}\text{C}$).

Ambient temperature of job side must be $5^{\circ}\text{C} < T_{\text{amb}} < 40^{\circ}\text{C}$

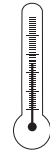
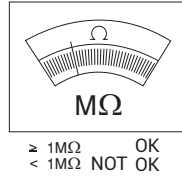

$< 5^{\circ}\text{C}$ → STOP
 $> 35^{\circ}\text{C}$ → STOP

$T(^{\circ}\text{C})$

Preparation of Mixture



Total mixture weight of 1 Bucket is 15 kg

15 kg.

When determining the material to be consumed for joint point, the installation of joint point weighing 15 kg and its multiples should be included in the workplan for the same day. Otherwise, since the remaining material will happen a curing reaction, it cannot be used in another day's work plan and will be scrapped. Material planning should be done taking this detail into consideration.



FILLER

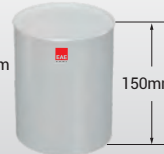

RESIN (A)



HARDENER (B)

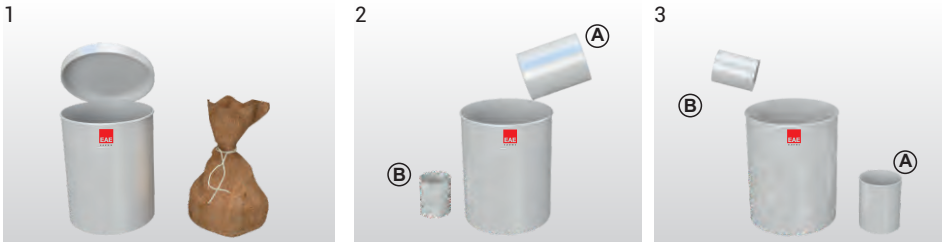

1 Filler removed from the plastic bucket.

2 Resin and hardener are mixed in plastic bucket.



4 Mix resin and hardener thoroughly with stirrer at least 30-60 seconds.



5 Add fillers and mix until homogeneous; at least 2-3 minutes. Then application must be done within 15 minutes.

950 A TO 2750 A MEDIUM VOLTAGE BUSBAR SYSTEMS (E- LINE MV) GENERAL PRODUCT SPECIFICATIONS

1- Standards & Certification:

- Busbar trunking system shall be designed in accordance with the international standards IEC 62271-200 and IEC 61439-6, type tests thereof shall be conducted and manufactured in accordance with the standard. Type tests shall be conducted by independent and accredited testing and certification bodies with international validity and certified accordingly. Short-circuit type tests and the following 3 main type tests shall be conducted for each current rating of busbar system and conformity certificate for the standards shall be obtained.

2- Overall System Structure

Busbar system should be with low impedance complying with the following specifications. This should be accomplished by placement of the tin coated conductors within the material with no entrapped air within.

2.1- Electrical Values

- Nominal insulation voltage of 12kV busbar trunking system should be 28kV.
- For the tin coated aluminum or copper, the environmental temperature should be maximum 40 °C while the maximum temperature rise should be 90 K.
- Minimum short circuit values of busbar should be as follows

For Cu Conductors;
950-2750A : phase-phase 1 sec.
value 25kA, peak value 65kA

2.2- Housing and Overall Structure

- Housing of busbar lengths is a special design and should be manufactured from a cast material.
- The structure of the busbar lengths shall have tin plated conductors along their complete length within the housing.
- In the busbar trunking system, there should be down-up and right-left turning elements, panel, transformer and cable connection elements, closure, horizontal and vertical expansion elements as a standard. Special modules and special size busbar lengths that may be required during the implementation of the project should be able to be manufactured within a short time and in accordance with the standard specification and technique.
- If busbar runs pass through the building expansion joint a horizontal expansion element shall be used in the run. Besides, horizontal dilatation element should be used at each 40 m on the horizontal lines.

2.3- Conductors and Phase Configuration

- Busbar trunking systems conductors shall be high conductivity copper with 99.95% / 99.99% between 950-2750A.
- Busbar trunking system should be in the following conductor number and phase configuration

a) 3 Conductors / PE housing

- Copper conductors should be 99.95% electrolytic copper. Minimum conductivity value should be 56 m/mm². Entire surfaces of the electrolytic copper conductors should be tin-coated.

2.4- Insulation Structure

- Bars with high conductivity value should be insulated with a special composite material composed of allot of specially selected sand, calcite and epoxy resin. This material should be compliant with temperature changes and thermal expansion. It should ensure high protection against external impacts.

2.5- Modular Joint Structure

- The phase conductors shall be joined using two junction plates per phase of suitable cross section to maintain the rating integrity of the conductors. These plates shall be secured using bolts with non-sharp tips torqued to 72 Nm. The joint shall be completed using a mixture of epoxy and silicon to match the material of the busbar lengths. This material should be compliant with temperature changes and thermal expansion. It should ensure high protection against external impacts. Juncture point bolts should be tightened with torque wrench set to 72 Nm (55 lbft)

2.6- Protection Class

- Busbar installations shall have the protection class of IP 68

3- Assembly and Commissioning Tests

- The assembly of the busbar trunking system should be performed in accordance with the electrical project , electrical single line diagram, layout plans and detailed busbar application projects in line with the type and current values indicated on these plans, instructions provided by the manufacturer should be strictly abided with during the assembly process. Joint bolts shall definitely be tightened by the torque wrench set to correct values and insulated accordingly.

- Upon the completion of the assembly of the busbar system and controlling of the compliance to the project thereof and assembly instructions;

- a) Di-Electric test with very low frequency should be conducted.
- b) Joint resistances and Line resistances should be measured.
- c) Phase sequences should be checked.

1500A TO 5700 A MEDIUM VOLTAGE BUSBAR SYSTEMS (E- LINE MV) GENERAL PRODUCT SPECIFICATIONS

1- Standards & Certification:

- Busbar trunking system shall be designed in accordance with international standards IEC 62271-200 and IEC 61439-6, type tests thereof shall be conducted and manufactured in accordance with the standard. Type tests shall be conducted by independent and accredited testing and certification bodies with international validity and certified accordingly. Short-circuit type tests and the following 3 main type tests shall be conducted for each current rating of busbar system and conformity certificate for the standards shall be obtained.

2- Overall System Structure

Busbar system should be with low impedance complying with the following specifications. This should be accomplished by placement of the tin coated conductors within the material with no entrapped air within.

2.1- Electrical Values

- 24kV Nominal insulation voltage of 24kV busbar trunking system should be 50kV.
- For the tin coated aluminum or copper, the environmental temperature should be maximum 40 °C while the maximum temperature rise should be 90 K.
- Minimum short circuit busbar lengths should be as follows.

For Al Conductors;

- 1500 A:1 sec. value 50 kA, peak value 130 kA
- 2000-3000 A:1 sec. value 72 kA, peak value 187 kA

For Cu Conductors;

- 1800-2100 A:1 sec. value 65 kA, peak value 169 kA
- 3200-5700 A:1 sec. value 72 kA, peak value 187 kA

2.2- Housing and Overall Structure

- Housing of busbar lengths is a special design and should be manufactured from a cast material.
- In the busbar trunking system, there should be down-up and right-left turning elements, panel, transformer and cable connection elements, closure, horizontal and vertical expansion elements as a standard. Special modules and special size busbar lengths that may be required during the implementation of the project should be able to be manufactured within a short time and in accordance with the standard specification and technique.
- The structure of the busbar lengths shall have tin plated conductors along their complete length within the housing.
- If busbar runs pass through the building expansion joint a horizontal expansion element shall be used in the run. In addition horizontal expansion elements should be used at each 40 m on the horizontal lines.

2.3- Conductors and Phase Configuration

- Busbar trunking system should be aluminum conductive between 1500-3000A.
- Busbar trunking system should be copper conductive between 1800-5700A.
- Busbar trunking systems conductors shall be high conductivity copper with.

a) 3 Conductors / PE housing

- Aluminum conductors must be in the EC-Grade class. The minimum conductivity must be 34 m/mm².... Entire surfaces of the aluminum conductors should be tin-coated.
- Copper conductors should be 99.99% electrolytic copper. Minimum conductivity value should be 56 m/mm². Entire surfaces of the electrolytic copper conductors should be tin-coated.

2.4- Insulation Structure

- Bars with high conductivity value should be insulated with a special composite material composed of allot of specially selected sand, calcite and epoxy resin. This material should be compliant with temperature changes and thermal expansion. It should ensure high protection against external impacts.

2.5- Modular Joint Structure

- The phase conductors shall be joined using two junction plates per phase of suitable cross section to maintain the rating integrity of the conductors. These plates shall be secured using bolts with non-sharp tips torqued to 72 Nm. The joint shall be completed using a mixture of epoxy and silicon to match the material of the busbar lengths. This material should be compliant with temperature changes and thermal expansion. It should ensure high protection against external impacts. Juncture point bolts should be tightened with torque wrench set to 72 Nm (55 lbft)

2.6- Protection Class

- Busbar installations shall have the protection class of IP 68.

3- Assembly and Commissioning Tests

- The assembly of the busbar trunking system should be performed in accordance with the electrical project , electrical single line diagram, layout plans and detailed busbar application projects in line with the type and current values indicated on these plans, instructions provided by the manufacturer should be strictly abided with during the assembly process. Joint bolts shall definitely be tightened by the torque wrench set to correct values and insulated accordingly.

- Upon the completion of the assembly of the busbar system and controlling of the compliance to the project thereof and assembly instructions;

- a) Di-Electric test with very low frequency should be conducted.
- b) Joint resistances and Line resistances should be measured.
- c) Phase sequences should be checked.

			
<p>14282.07-M</p> <p>ik Asansör İnşaat San. ve Tjç. A.Ş. z Mahalle / İsta</p>			
			
<p>17</p> <p>HİNC</p> <p>ltage busb: (busway)</p>			
			
<p>2017</p> <p>ik Asansör . ve Tjç. A.Ş. z Mahallesi anyurt / İsta</p>			
			
<p>ification</p> <p>-200 Editio -6 Editio -307 Editio : to IEC 62</p> <p>t complis</p>			
			
<p>00</p> <p>requiremer</p> <p>0 2011-10</p>			

EAE Elektrik A.S.
Head Office
Akcaburgaz Mahallesi,
3114. Sokak, No:10 34522
Esenyurt - Istanbul - TURKEY
Tel: +90 (212) 866 20 00
Fax: +90 (212) 886 24 20

EAE DL 3 Factory
Busbar
Gebze IV Istanbul Makine ve
Sanayicileri
Organize Bolgesi, 6. Cadde,
No: 6 41455 Demirciler Koyu,
Dilovası - Kocaeli - TURKEY
Tel: +90 (262) 999 05 55
Fax: +90 (262) 502 05 69



MV Manuel / En. / Rev 04 1.000 pcs 17/12/2024

N.G

EAE has full right to make any revisions or changes on this catalogue without any prior notice.